

Axial piston fixed motor A2FM/A2FE/ A2FMT

Series 70

Instruction manual
RE 91071-01-B/06.2018

Replaces: 03.2015
English

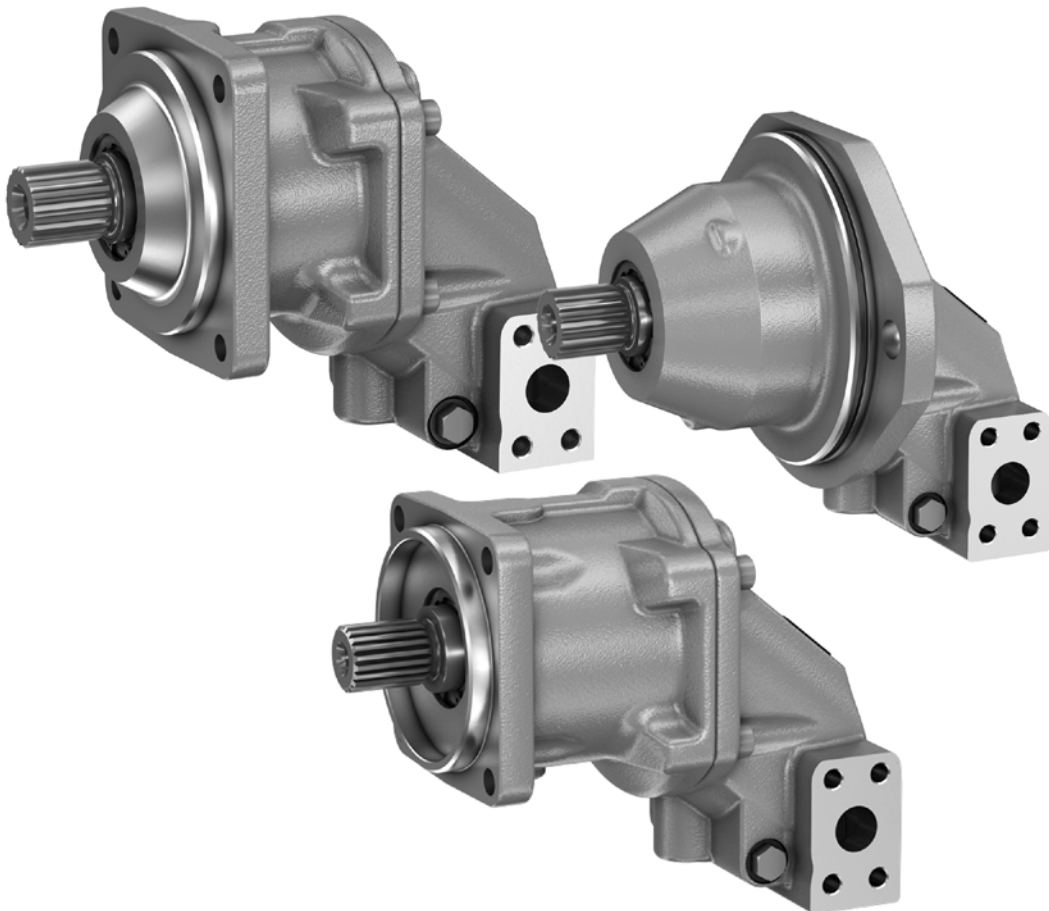

© Bosch Rexroth AG 2018. All rights reserved, also regarding any disposal, exploitation, reproduction, editing, distribution, as well as in the event of applications for industrial property rights. The data specified within only serves to describe the product. No statements concerning a certain condition or suitability for a certain application can be derived from our information. The information given does not release the user from the obligation of own judgment and verification. It must be remembered that our products are subject to a natural process of wear and aging.

The cover shows an example application. The product delivered may differ from the image on the cover.

The original instruction manual was created in the German language.

Contents

1	About this manual	5
1.1	Applicability	5
1.2	Required and supplementary documentation	5
1.3	Representation of information	6
1.3.1	Safety instructions	6
1.3.2	Symbols	6
1.3.3	Designations	7
1.3.4	Abbreviations	7
2	Safety instructions	8
2.1	About this chapter	8
2.2	Intended use	8
2.3	Improper use	8
2.4	Personnel qualifications	9
2.5	General safety instructions	10
2.6	Product-specific safety instructions	11
2.7	Personal protective equipment	13
3	General notices regarding property and product damage	14
4	Scope of delivery	17
5	About this product	18
5.1	Performance description	18
5.2	Product description	18
5.2.1	Axial piston unit layout	18
5.2.2	Functional description	19
5.3	Product identification	19
6	Transport and storage	20
6.1	Transporting the axial piston unit	20
6.1.1	Transporting by hand	21
6.1.2	Transporting with a lifting device	21
6.2	Storing the axial piston unit	22
7	Installation	25
7.1	Unpacking	25
7.2	Installation conditions	25
7.3	Installation position	26
7.3.1	Below-reservoir installation (standard)	26
7.3.2	Above-reservoir installation	27
7.4	Installing the axial piston unit	28
7.4.1	Preparation	28
7.4.2	Dimensions	28
7.4.3	General instructions	29
7.4.4	Installation with a clutch	29
7.4.5	Installation on a gearbox	30
7.4.6	Completing installation	30
7.4.7	Hydraulically connecting the axial piston unit	31
7.5	Performing flushing cycle	38

8	Commissioning	39
8.1	Initial commissioning	39
8.1.1	Filling the axial piston unit	40
8.1.2	Testing the hydraulic fluid supply	41
8.1.3	Performing a functional test	41
8.2	Running-in phase	42
8.3	Recommissioning after standstill	42
9	Operation	43
10	Maintenance and repair	44
10.1	Cleaning and care	44
10.2	Inspection	45
10.3	Maintenance	45
10.4	Repair	46
10.5	Spare parts	46
11	Removal and replacement	47
11.1	Required tools	47
11.2	Preparing for removal	47
11.3	Removal	47
11.4	Preparing the components for storage or further use	47
12	Disposal	48
13	Extension and conversion	48
14	Troubleshooting	49
14.1	How to troubleshoot	49
14.2	Malfunction table	50
15	Technical data	52
16	Alphabetical index	54

1 About this manual

1.1 Applicability

This manual applies to the following products:

- Axial piston fixed motor A2FM series 70 (standard version)
- Axial piston fixed motor A2FE series 70 (plug-in version)
- Axial piston fixed motor A2FMT series 70 (for drum drives)

This manual is intended for machine/system manufacturers, assemblers and service engineers.

It contains important information on the safe and appropriate transport, installation, commissioning, operation, maintenance, removal and simple troubleshooting of the axial piston unit.

- ▶ Read this manual completely, in particular Chapter 2 “Safety instructions” on page 8 and Chapter 3 “General notices regarding property and product damage” on page 14 before you start work with the axial piston unit.

1.2 Required and supplementary documentation







- ▶ Only commission the axial piston unit if the documentation marked with the book symbol  is available to you and you have understood and observed it.

Table 1: Required and supplementary documentation

Title	Document number	Document type
 Order confirmation Contains the order-related technical data of your A2FM, A2FE or A2FMT axial piston fixed motor.	–	Order confirmation
 Installation drawing Contains the outer dimensions, all connections and the hydraulic schematic of your A2FM, A2FE or A2FMT axial piston fixed motor.	Please request the installation drawing from your contact at Bosch Rexroth.	Installation drawing
 Axial piston fixed motor A2FM, axial piston plug-in motor A2FE series 70 Contains the permissible technical data.	91071	Data sheet
 Axial piston fixed motor A2FMT series 70 Contains the permissible technical data.	91072	Data sheet
DSM speed sensor series 10	95132	Data sheet
DSA speed sensor series 12	95133	Data sheet
Counterbalance valve BVD	95522	Data sheet
 Mineral oil-based hydraulic fluids and related hydrocarbons Describes the requirements on a mineral oil-based hydraulic fluid and related hydrocarbons for operation with Rexroth hydraulic components and assists you in selecting a hydraulic fluid for your hydraulic system.	90220	Data sheet
 Environmentally acceptable hydraulic fluids Describes the requirements on an environmentally acceptable hydraulic fluid for operation with Rexroth hydraulic components and assists you in selecting a hydraulic fluid for your hydraulic system.	90221	Data sheet
Information on the use of hydrostatic drives at low temperatures Contains additional information on the use of Rexroth axial piston units at low temperatures.	90300-03-B	Manual
Storage and preservation of axial piston units Contains additional information on storage and preservation.	90312	Data sheet

1.3 Representation of information

Standardized safety instructions, symbols, terms and abbreviations are used throughout this manual so that you can work quickly and safely with your product. For clarification, they are explained in the sections below.

1.3.1 Safety instructions



This manual contains safety instructions in Chapter 2.6 “Product-specific safety instructions” on page 11 and in Chapter 3 “General notices regarding property and product damage” on page 14, as well as before a sequence of actions or an instruction for action involving a risk of personal injury or property damage. Always follow the instructions on avoiding the dangers associated with the use of this product.

Safety instructions are set out as follows:

 SIGNAL WORD
<p>Type and source of danger! Consequences of noncompliance</p> <ul style="list-style-type: none"> ▶ Measures to prevent danger

- **Warning sign:** draws attention to the danger
- **Signal word:** identifies the degree of the danger
- **Type and source of danger:** indicates the type and source of the danger
- **Consequences:** describes what occurs if safety instructions are not complied with
- **Precautions:** states how the danger can be avoided

Table 2: Danger classes as defined in ANSI Z535.6

Warning sign, signal word	Meaning
 DANGER	Identifies a dangerous situation that will result in death or serious injury if it is not avoided.
 WARNING	Identifies a dangerous situation that may result in death or serious injury if it is not avoided.
 CAUTION	Identifies a dangerous situation that may result in minor to moderate injury if it is not avoided.
NOTICE	Property damage: The product or the environment may get damaged.

1.3.2 Symbols

The following symbols indicate information that is not safety-relevant but increases understanding of the manual.

Table 3: Meaning of symbols

Symbol	Meaning
	If this information is disregarded, the product cannot be used and/or operated to its full extent.
▶	Single, independent action
1.	Numbered instruction:
2.	The numbers indicate that the actions must be completed in order.
3.	

1.3.3 Designations

This documentation uses the following designations:

Table 4: Designations

Designation	Meaning
A2FM	Axial piston fixed motor in standard version, open and closed circuit
A2FE	Axial piston fixed motor in plug-in version, open and closed circuit
A2FMT	Axial piston fixed motor, closed circuit, for use in concrete mixer trucks
Threaded plug	Metal screw, pressure-resistant
Protective plug	Made out of plastic, not pressure-resistant, only for transportation

The designation “axial piston unit” is used from this point forward as a generic term for the “A2FM axial piston fixed motor”, “A2FE axial piston plug-in motor” or “A2FMT axial piston fixed motor”.

1.3.4 Abbreviations

This manual uses the following abbreviations:

Table 5: Abbreviations

Abbreviation	Meaning
ATEX	EC directive on explosion protection (A tmosphère e xplosible)
DIN	D eutsches Institut für N ormung (German Institute for Standardization)
ISO	I nternational O rganization for S tandardization
JIS	J apan I ndustrial S tandard
RE	R exroth document in the E nglish language
VDI 2230	Standard for systematically calculating heavy-duty threaded connections and cylindrical screwed connections from the VDI (V erein D eutscher I ngenieur e – Association of German Engineers)

2 Safety instructions

2.1 About this chapter

The axial piston unit has been manufactured to generally accepted engineering standards. There is still, however, a risk of personal injury or property damage if this chapter and the safety instructions in this manual are not observed.

- ▶ Read this manual completely and thoroughly before working with the axial piston unit.
- ▶ Keep it in a location where it is accessible to all users at all times.
- ▶ Always include the required documentation when you pass the axial piston unit on to third parties.

2.2 Intended use

Axial piston units are hydraulic components, meaning that in their application area they are classified neither as complete nor as partly completed machinery as defined in the EC Machinery Directive (2006/42/EC). The component is exclusively intended to form partly completed machinery or complete machinery together with other components. The component may only be commissioned after it has been installed in the machine/system for which it is intended and the safety of the entire system has been established in accordance with the Machinery Directive.

This product is intended for the following use:

The A2FM and A2FE axial piston units are only approved as hydraulic motors in hydrostatic drives.

The A2FMT axial piston unit is only approved as a hydraulic motor for hydrostatic drum drives in a closed circuit in concrete mixer trucks.

- ▶ Observe the technical data, the application and operating conditions, and the performance limits as specified in data sheet 91071/91072 and in the order confirmation. Information on approved hydraulic fluids can be found in data sheets 91071 and 91072.

The axial piston unit is only intended for commercial use and not for private use. Intended use includes having fully read and understood this manual, especially Chapter 2 "Safety instructions" on page 8.

2.3 Improper use

Any use other than that described as intended use is considered improper.

Bosch Rexroth AG is not liable for damages resulting from improper use. The user is solely responsible for any risks arising from improper use.

The following foreseeable misuses are also considered improper (this list is not exhaustive):

- Use outside the operating parameters approved in the data sheet or in the order confirmation (unless specifically approved by the customer)
- Use of non-approved fluids, e.g. water or polyurethane components
- Changes to factory settings by unauthorized persons
- Use of assembled parts (e.g. control unit, valves) not in combination with the specified Rexroth components

- Use of the axial piston unit with assembled parts under water at a depth of more than 10 meters without the necessary additional measures, e.g. pressure equalization Units with electrical components (e.g. sensors) generally cannot come into contact with water
- Use of the axial piston unit under a continuous pressure differential between housing and ambient pressure greater than 2 bar, with the ambient pressure always lower than the case pressure. Momentary ($t < 0.1$ s) pressure peaks of up to 10 bar are permissible. Beyond this, the maximum permissible case pressure specified in the data sheet should not be exceeded.
- Use of the axial piston unit in explosive environments unless the component or machine/system has been certified as compliant with the ATEX directive 2014/34/EC
- Use of the axial piston unit in a corrosive atmosphere
- Use of the axial piston unit in aircraft or spacecraft

2.4 Personnel qualifications

The activities described in this manual require a basic understanding of mechanics, electricity and hydraulics, as well as familiarity with associated technical terms. For transporting and handling the product, additional familiarity with the use of lifting devices and lifting accessories is required. In order to ensure safe use, these activities should only be performed by qualified personnel or an instructed person under the direction and supervision of qualified personnel.

Qualified personnel refers to persons who possess the professional training, knowledge and experience, as well as the understanding of the regulations relevant to the work to be done that are necessary to recognize possible hazards and take the appropriate safety measures. Qualified personnel must follow the rules relevant to their field and have the necessary hydraulics expertise.

Expertise in hydraulics includes:

- Being able to read and fully understand hydraulic circuit diagrams
- In particular, fully understanding the relationships with regard to safety devices
- Understanding how hydraulic components work and are put together



Bosch Rexroth offers training support for specialized fields. An overview of the training contents can be found online at: www.boschrexroth.com/training.

2.5 General safety instructions

- Observe the applicable accident prevention and environmental protection regulations.
- Observe the safety regulations and provisions of the country in which the product is used/operated.
- Use Rexroth products only when they are in good working order.
- Observe all notices on the product.
- Do not install, operate, remove or maintain Rexroth products if under the influence of alcohol, drugs or medication that may affect your reaction time.
- Only use genuine Rexroth accessories and spare parts to ensure there is no hazard to persons due to unsuitable spare parts.
- Observe the technical data and ambient conditions specified in the product documentation.
- If unsuitable products are installed or used in applications that are of relevance to safety, unexpected operating conditions may occur in the application, which could result in personal injury or property damage. For this reason, only use the product in safety-relevant applications if this use is expressly indicated and approved in the product documentation, e.g. in explosion protection applications or in safety-related parts of a control system (functional safety).
- Only commission the product if it has been determined that the end product (e.g. machinery or system) in which the Rexroth products are installed complies with the country-specific provisions, safety regulations and standards for the application.
- Use tools appropriate for the work being performed and wear appropriate protective clothing to prevent punctures and cuts (e.g. when removing protective covers, disassembly).
- There is a risk of entanglement when operating the axial piston unit with a bare shaft end. Check whether or not your machine requires additional safety measures for your application. If necessary, make sure that these are properly implemented.

2.6 Product-specific safety instructions

The following safety instructions apply to chapters 6 to 14.

WARNING

Danger from excessively high pressure!

Risk of death or injury, or property damage!

Improperly changing the factory pressure settings can result in a pressure increase beyond the maximum permissible pressure.

Operating the unit above the maximum permissible pressure can cause components to burst and hydraulic fluid to escape under high pressure.

- ▶ Changes to the factory settings should only be made by Bosch Rexroth specialists.
- ▶ In addition, a pressure relief valve is required in the hydraulic system as a back-up. If the axial piston unit is equipped with a pressure cut-off and/or a pressure controller, this is not an adequate back-up against pressure overload.

Danger from suspended loads!

Risk of death or injury, or property damage!

Improper transportation may cause the axial piston unit to fall down and lead to injury, e.g. crushing or fracture, or damage to the product.

- ▶ Make sure that the load bearing capacity of the lifting device is sufficient to safely bear the weight of the axial piston unit.
- ▶ Never stand or put your hands under a suspended load.
- ▶ Make sure the unit remains stable during transport.
- ▶ Wear your personal protective equipment (e.g. safety goggles, safety gloves, suitable working clothes, safety shoes).
- ▶ Use suitable lifting devices for transportation.
- ▶ Observe the prescribed position of the lifting strap.
- ▶ Observe the national laws and regulations on work and health protection and transportation.

System/machine under pressure!

Risk of death or serious injury when working on unsecured machines/systems! Risk of property damage!

- ▶ Switch off the entire system and secure it against reactivation according to the parameters provided by the machine/system manufacturer.
- ▶ Make sure that all relevant components of the hydraulic system are depressurized. Follow the machine/system manufacturer's specifications.
- ▶ Note that the hydraulic system may still be under pressure even after the pressure supply itself has been disconnected.
- ▶ Do not disconnect any line connections, ports and components as long as the hydraulic system is under pressure.

WARNING

Escaping hydraulic fluid mist!

Risk of explosion and fire, health hazard, risk of environmental pollution!

- ▶ Depressurize the relevant machine/system component and repair the leak.
- ▶ Only perform welding work when the machine/system is depressurized.
- ▶ Keep open flames and ignition sources away from the axial piston unit.
- ▶ If axial piston units are located in the vicinity of ignition sources or powerful thermal radiators, a shield must be erected to ensure that any escaped hydraulic fluid cannot be ignited, and to protect hose lines from premature aging.

Electrical voltage!

Risk of injury from electric shock or risk of property damage!

- ▶ Always disconnect the relevant part of the machine/system before installing the product or when inserting/removing connectors. Protect the machine/system against being re-energized.

Limitation of load holding function in lifting winches!

Risk of injury or property damage!

Moving parts in high-pressure relief valves may in certain circumstances become stuck in an undefined position due to contamination (e.g. impure hydraulic fluid). This can result in limitation or loss of the load holding function in lifting winches.

- ▶ Check whether the application on your machine requires additional safety measures in order to keep the load in a safe position.
- ▶ If necessary, make sure that these are properly implemented.

CAUTION

High noise development during operation!

Risk of hearing damage or hearing loss!

The noise emission of axial piston units depends on, among other factors, rotational speed, working pressure and installation conditions. The sound pressure level may rise above 70 dB (A) in certain application conditions.

- ▶ Always wear hearing protection when in the vicinity of the operating axial piston unit.

Hot surfaces on axial piston unit!

Risk of burning!

- ▶ Allow the axial piston unit to cool down sufficiently before touching it.
- ▶ Wear heat-resistant protective clothing, e.g. gloves.

Improper cable and line routing!

Risk of stumbling and property damage! Improper routing of cables and lines can cause a risk of stumbling as well as damage to equipment and components, e.g. due to lines and connectors being torn off.

- ▶ Always lay cables and lines in such a way that no one can trip over them, that they do not become kinked or twisted, do not rub on edges and do not run without adequate protection through sharp-edged ducts.

CAUTION

Contact with hydraulic fluid!

Risk of adverse health effects, e.g. eye injury, skin irritation, poisoning from inhalation!

- ▶ Avoid contact with hydraulic fluids.
- ▶ When working with hydraulic fluids, strictly observe the safety instructions provided by the lubricant manufacturer.
- ▶ Wear your personal protective equipment (e.g. safety goggles, safety gloves, suitable working clothes, safety shoes).
- ▶ Consult a doctor immediately if hydraulic fluid gets in your eyes or bloodstream, or is swallowed.

Escaping hydraulic fluid due to leakage from machine/system components!

Risk of burning and injury due to escaping hydraulic fluid jet!

- ▶ Depressurize the relevant machine/system component and repair the leak.
- ▶ Never attempt to block or seal the leak or hydraulic fluid jet with a cloth.

Danger from improper handling!

Risk of slipping! Risk of slipping on wet surfaces when climbing on the axial piston unit.

- ▶ Never grab or climb onto the axial piston unit.
- ▶ Check how to safely get on top of the machine/system.

2.7 Personal protective equipment

Personal protective equipment is the responsibility of the user of the axial piston unit. Observe the safety regulations in your country.

All pieces of personal protective equipment should be intact.

3 General notices regarding property and product damage

The following instructions apply to chapters 6 to 14.

NOTICE

Danger from improper handling!

Product can be damaged!

- ▶ Do not expose the product to excessive mechanical loads.
- ▶ Never grab or climb onto the product.
- ▶ Do not place/lay any objects on the product.
- ▶ Do not strike the drive shaft of the axial piston unit.
- ▶ Do not set/place the axial piston unit on the drive shaft or assembled parts.
- ▶ Do not strike assembled parts (e.g. sensors or valves).
- ▶ Do not strike sealing surfaces (e.g. at working ports).
- ▶ Leave the protective covers on the axial piston unit until you connect the lines.
- ▶ Disconnect all electrical connectors before arc welding or painting.
- ▶ Make sure that the electronic components (e.g. sensors) do not build up electrostatic charges (e.g. during painting).

Risk of property damage due to inadequate lubrication!

Product can be damaged or destroyed!

- ▶ Never operate the axial piston unit with insufficient hydraulic fluid. Specifically, make sure that the rotary group has sufficient lubrication.
- ▶ When commissioning a machine/system, make sure that the housing area and the working lines of the axial piston unit are filled with hydraulic fluid and remain filled during operation. Avoid air inclusions in the forward drive shaft bearing, especially with the axial piston unit installed with the drive shaft up.
- ▶ Check the hydraulic fluid level in the housing area regularly and recommission, if necessary. For above-reservoir installation, the housing area may drain out through the drain line after prolonged standstill periods (air enters through the shaft seal) or through the working line (gap leakage). This means the bearings are insufficiently lubricated when the system is turned on.

Mixing of hydraulic fluids!

Product can be damaged!

- ▶ Before installation, remove all fluids from the axial piston unit to prevent mixing with the hydraulic fluid used in the machine/system.
- ▶ Never mix hydraulic fluids from different manufacturers or different types from the same manufacturer.

NOTICE

Contamination of hydraulic fluid!

The cleanliness of the hydraulic fluid has a considerable impact on the cleanliness and service life of the hydraulic system. Contamination of the hydraulic fluid can cause premature wear and malfunctions!

- ▶ Make sure that the working environment at the installation site is completely free of dust and foreign substances in order to prevent foreign particles, such as welding beads or metal cuttings, from getting into the hydraulic lines and causing product wear or malfunctions. The axial piston unit should be clean when installed.
- ▶ Use only clean connections, hydraulic lines and assembled parts (e.g. measuring devices).
- ▶ Do not allow any contamination into the ports when they are being plugged.
- ▶ Before commissioning, make sure that all hydraulic connections are tight and that all of the seals and plug-in connections are installed correctly to ensure that they are leak-proof, and fluids and foreign particles cannot enter into the product.
- ▶ Use a suitable filter system to filter hydraulic fluid during filling to minimize solid particle contamination and water in the hydraulic system.

Improper cleaning!

Product can be damaged!

- ▶ Close all openings with appropriate protective covers in order to prevent cleaning agents from entering the hydraulic system.
- ▶ Never use solvents or corrosive cleaning agents. Use only water and, if necessary, a mild cleaning agent to clean the axial piston unit.
- ▶ Do not point a high-pressure cleaner at sensitive components, e.g. shaft seal, electrical connections and components.
- ▶ Use fiber-free cloths for cleaning.

Environmental pollution due to improper disposal!

Careless disposal of the axial piston unit and its assembled parts, the hydraulic fluid and the packaging material can result in environmental pollution!

- ▶ Dispose of the axial piston unit, hydraulic fluid and packaging in accordance with the regulations in your country.
- ▶ Dispose of the hydraulic fluid in accordance with the applicable safety data sheet for the hydraulic fluid.

Danger from chemical or corrosive environmental conditions!

Product can be damaged! If the axial piston unit is exposed to chemical or corrosive environmental conditions, such as sea water, fertilizer or road salt, it can result in corrosion or, in extreme cases, malfunction. Hydraulic fluid can escape if leaks occur.

- ▶ Take appropriate steps to protect the axial piston unit from chemical or corrosive environmental conditions.

NOTICE

Escaping or spilling hydraulic fluid!

Risk of environmental pollution and contamination of ground water!

- ▶ Always place a drip tray under the axial piston unit when adding and draining the hydraulic fluid.
- ▶ Use a suitable binding agent if hydraulic fluid is spilled.
- ▶ Observe the safety data sheet for the hydraulic fluid and the specifications provided by the system manufacturer.

Danger from hot components!

Nearby products can be damaged! Components that heat up (e.g. solenoids) can cause damage to nearby products if they are too close.

- ▶ When installing the axial piston unit, check the distances to nearby products to ensure that they are not damaged.

The warranty only applies to the machine as delivered.

The warranty will be voided if the product is incorrectly installed, commissioned or operated, or if it is used or handled improperly.

4 Scope of delivery

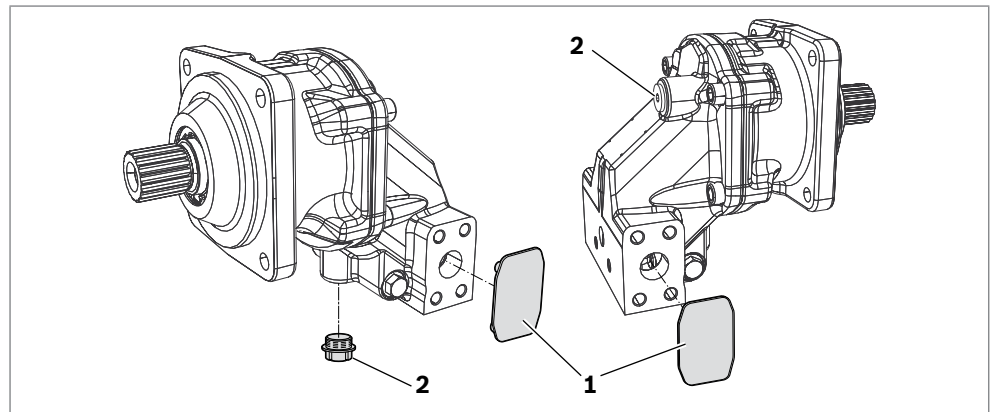

Fig. 1: Axial piston unit

The scope of delivery includes the following:

- Axial piston unit as per order confirmation

The following parts come assembled on the unit:

- Protective covers **(1)**
- Protective/threaded plugs **(2)**

5 About this product

5.1 Performance description

An axial piston fixed motor converts hydrostatic flow into mechanical rotation. It is designed for mobile and stationary applications.

Refer to data sheets 91071 and 91072, and the order confirmation for the technical data, operating conditions and operating limits of the axial piston unit.

5.2 Product description

The fixed motor is available in the A2FM standard version and the A2FE plug-in version. The A2FM/A2FE is a fixed motor with an axial tapered piston rotary group with a bent-axis design for hydrostatic drives in open and closed circuits. The A2FMT is a fixed motor with an axial tapered piston rotary group with a bent-axis design for closed-circuit hydrostatic drum drives in concrete mixer trucks. In axial piston units with a bent-axis design, the pistons (**2**) are arranged at an angle to the drive shaft (**1**). The pistons rest directly on the drive shaft where they generate torque depending on the pressure.

Open circuit In an open circuit, the hydraulic fluid flows from the reservoir to the hydraulic pump, where it is transported to the hydraulic motor. The hydraulic fluid flows from the hydraulic motor directly back to the reservoir. The output direction the hydraulic motor can be changed with a directional valve.

Closed circuit In the closed circuit, the hydraulic fluid flows from the hydraulic pump to the hydraulic motor, then directly back to the hydraulic pump. The output direction of the hydraulic motor can be changed, e.g. by reversing the flow direction in the hydraulic pump.

5.2.1 Axial piston unit layout

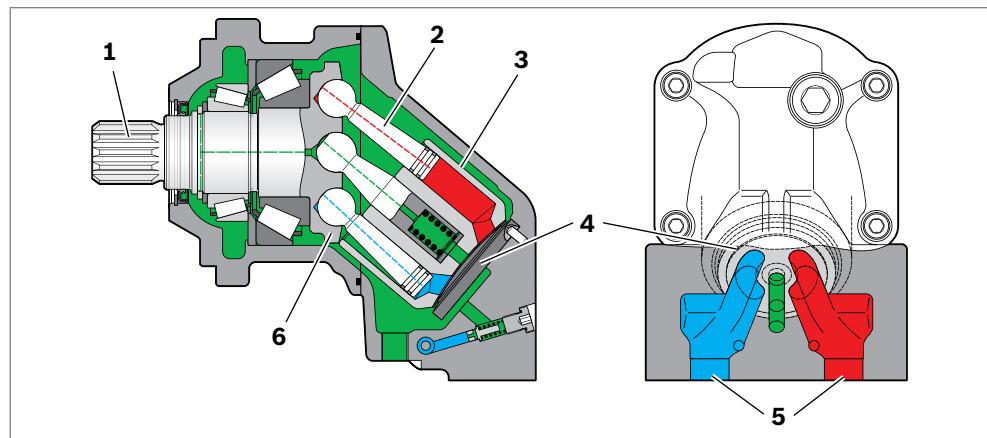

Fig. 2: Series 70 A2FM layout

- | | | |
|----------------------|------------------------|-----------------------------|
| 1 Drive shaft | 3 Cylinder | 5 Working ports |
| 2 Piston | 4 Control plate | 6 Drive shaft flange |

5.2.2 Functional description

Motor function

A hydraulic motor converts hydrostatic energy into mechanical energy. Hydraulic fluid is fed to the cylinder bores through the working ports (5) and the control plate (4). The pistons (2) in the cylinder bores complete a stroke that is converted into rotary movement by the pistons on the drive shaft flange (6). During this process, the pistons move the cylinder (3) and generate output torque on the drive shaft. This output torque increases with the pressure difference between the high-pressure and low-pressure sides. The output speed is proportional to the inward flow and inversely proportional to the displacement of the hydraulic motor.

5.3 Product identification

The axial piston unit can be identified by the name plate. The following example shows an A2FM name plate:

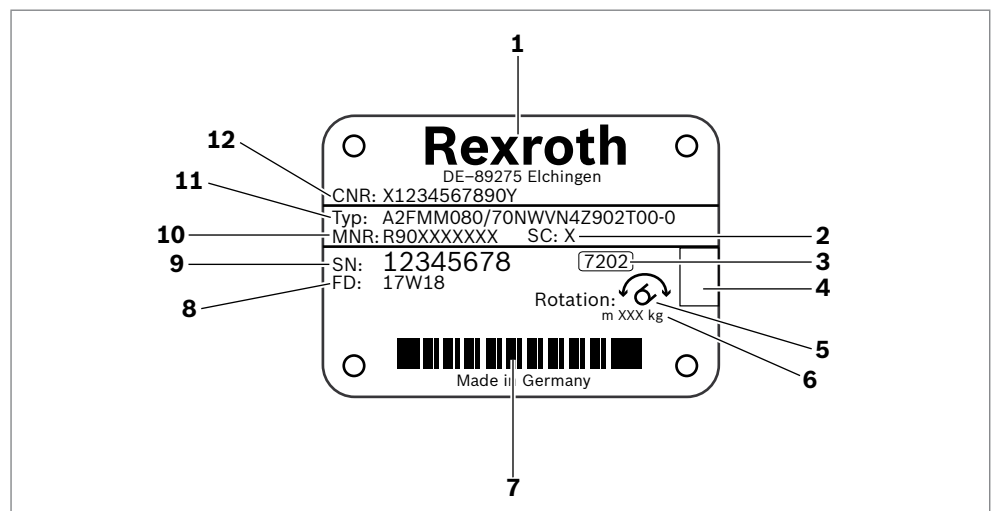

Fig. 3: A2FM name plate

- | | |
|-------------------------------------------------------------------------------|----------------------------------------------------|
| 1 Manufacturer | 7 Bar code |
| 2 Sample category (optional) | 8 Manufacturing date |
| 3 Internal factory designation | 9 Serial number |
| 4 Designated area for inspection stamp | 10 Material number of the axial piston unit |
| 5 Direction of rotation (viewed on drive shaft) – here: bi-directional | 11 Type code |
| 6 Weight (optional) | 12 Customer material number |

6 Transport and storage

- ▶ Always observe the necessary ambient conditions for transport and storage, see chapter 6.2 “Storing the axial piston unit” on page 22.



Information on unpacking can be found in chapter 7.1 “Unpacking” on page 25.

6.1 Transporting the axial piston unit

The following transportation options are available depending on weight and duration of transport:

- Transporting by hand (chapter not relevant for this axial piston unit)
- Transporting with a lifting device (eye bolt or lifting strap)

Dimensions and weights

Table 6: Dimensions and weights for A2FMN/A2FEN
Nominal pressure 300 bar, max. pressure 350 bar

Size		56	63	80	90	107
Weight	kg	17	17	17	23	23
Width	mm	Dimensions vary by equipment. The values applicable for your axial piston unit can be found in the installation drawing (request if necessary).				
Height	mm					
Depth	mm					

Table 7: Dimensions and weights for A2FMM/A2FEM
Nominal pressure 400 bar, max. pressure 450 bar

Size		45	56	63	80	90
Weight	kg	17	17	17	23	23
Width	mm	Dimensions vary by equipment. The values applicable for your axial piston unit can be found in the installation drawing (request if necessary).				
Height	mm					
Depth	mm					

Table 8: Dimensions and weights for A2FMH/A2FEH
Nominal pressure 450 bar, max. pressure 500 bar

Size		45	56	63	80	90
Weight	kg	17	17	17	23	23
Width	mm	Dimensions vary by equipment. The values applicable for your axial piston unit can be found in the installation drawing (request if necessary).				
Height	mm					
Depth	mm					

Table 9: Dimensions and weights for A2FMT
Max. pressure 420 bar

Size		56	63	80	90	107
Weight	kg	17	17	17	23	23
Width	mm	Dimensions vary by equipment. The values applicable for your axial piston unit can be found in the installation drawing (request if necessary).				
Height	mm					
Depth	mm					

Weight may vary by equipment.

6.1.1 Transporting by hand

Axial piston units with a weight of up to 15 kg can be transported by hand for a short time, if necessary.

CAUTION! Danger from heavy loads!

Health hazard from carrying axial piston units.

- ▶ Use appropriate lifting, lowering and moving techniques.
- ▶ Wear your personal protective equipment (e.g. safety goggles, safety gloves, suitable working clothes, safety shoes).
- ▶ Do not transport the axial piston unit by sensitive assembled parts (e.g. sensors or valves).
- ▶ Carefully place the axial piston unit on the seating to prevent it from being damaged.

6.1.2 Transporting with a lifting device

For transporting, the axial piston unit can be connected to a lifting device via an eye bolt or a lifting strap.

Transport with eye bolt

The axial piston unit can be transported suspended from an eye bolt screwed into the drive shaft as long as only outward (pulling) axial forces are applied.

- ▶ For all female threads, use a stud end from the same system of units and of the correct size.
- ▶ To do this, screw an eye bolt completely into the female thread on the drive shaft. The thread size is indicated in the installation drawing.
- ▶ Make sure that the eye bolt can bear the total weight of the axial piston unit plus 20%.

You can lift the axial piston unit as shown in Fig. 4 with the eye bolt screwed into the drive shaft.

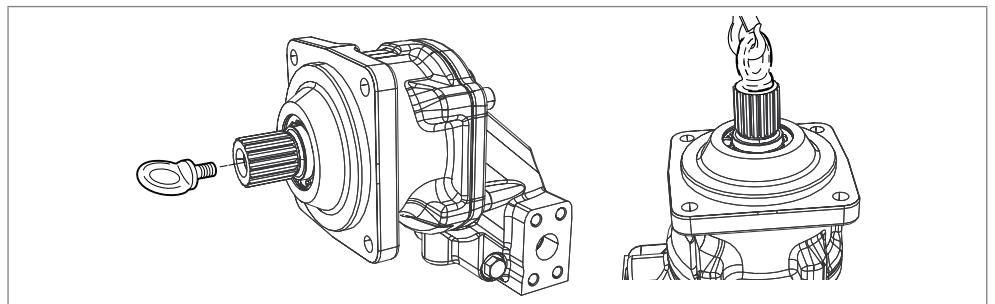

Fig. 4: Installing the eye bolt

Transport with lifting strap**WARNING!** Danger from suspended loads!

During transport with a lifting device, the axial piston unit can topple out of the lifting strap and cause injury.

- ▶ Use the widest possible lifting strap.
 - ▶ Make sure that the axial piston unit is securely fixed with the lifting strap.
 - ▶ Only guide the axial piston unit by hand for fine positioning and to avoid swinging.
 - ▶ Never stand or put your hands under a suspended load.
-
- ▶ Place the lifting strap around the axial piston unit in such a way that it does not pass over assembled parts (e.g. valves, piping) and that the axial piston unit is not suspended from assembled parts (see Fig. 5).

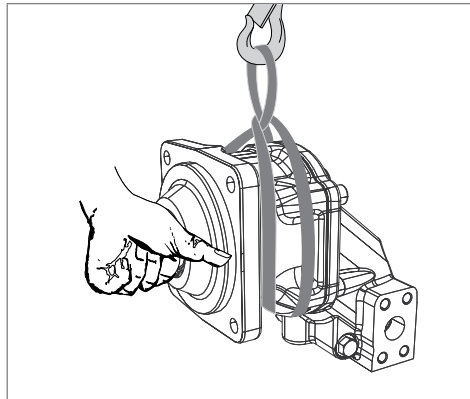

Fig. 5: Transporting with lifting strap

6.2 Storing the axial piston unit

Requirements

- Storage areas should be free of corrosive materials and gases.
 - To prevent damage to the seals, do not operate ozone-forming equipment (e.g. mercury-vapor lamps, high-voltage equipment, electric motors, sources of electrical sparks or electrical discharge) in storage areas.
 - Storage areas should be dry.
Recommended relative humidity $\leq 60\%$.
 - Ideal storage temperature: +5 °C to +20 °C.
 - Min. storage temperature: -50 °C.
 - Max. storage temperature: +60 °C.
 - Keep out of direct sunlight.
 - Do not stack axial piston units and store them in a shock-proof manner.
 - Do not store the axial piston unit on the drive shaft or on assembled parts, e.g. sensors or valves.
 - For further storage conditions, see Table 10.
-
- ▶ Check the axial piston unit monthly to ensure proper storage.

After delivery The axial piston units come in corrosion protection packaging (corrosion protection film).
Table 10 lists the maximum permissible storage times for an unpackaged axial piston unit as per data sheet 90312.

Table 10: Storage time with factory corrosion protection

Storage conditions	Standard corrosion protection	Long-term corrosion protection (optional)
Closed, dry room, at a consistent temperature between +5 °C and +20 °C. Undamaged and sealed corrosion protection film.	Max. 12 months	Max. 24 months



The warranty will be voided if the requirements and storage conditions are not observed or after expiration of the max. storage time (see Table 10).

What to do once the max. storage time elapses:

1. Check the entire axial piston unit for damage and corrosion prior to installation.
2. Perform a test run to check the axial piston unit for proper function and leaks.
3. If storage time exceeds 24 months, replace the shaft seal.



Once the max. storage time has elapsed, we recommend that you have the axial piston unit inspected by your Bosch Rexroth service partner.

For questions regarding repair and spare parts, contact your proper Bosch Rexroth service partner or the service department of the factory that manufactured the axial piston unit, see chapter 10.5 “Spare parts” on page 46.

After removal An uninstalled axial piston unit must be preserved with corrosion protection for the duration of storage.



The following instructions only refer to axial piston units operated with a mineral oil-based hydraulic fluid. Other hydraulic fluids require preservation measures specifically designed for them. If using another hydraulic fluid, consult your local contact person. You can find their contact information under www.boschrexroth.com/addresses

Bosch Rexroth recommends the following procedure:

1. Clean the axial piston unit; see chapter 10.1 “Cleaning and care” on page 44.
2. Drain the axial piston unit.
3. For storage periods up to 12 months: Coat the inside of the axial piston unit with mineral oil and fill with about 100 mL of mineral oil.
For storage periods up to 24 months: Fill the axial piston unit with VCI 329 corrosion protection (20 mL).
Fill through the drain port **T₁** or **T₂**; see chapter 7.4 “Installing the axial piston unit”, Fig. 12 to Fig. 14 on page 35.
4. Plug all ports so they are airtight.
5. Coat unpainted areas of the axial piston unit with mineral oil or suitable, easily removable corrosion protection, e.g. acid-free grease.
6. Package the axial piston unit with desiccant in corrosion protection film so it is airtight.
7. Store the axial piston unit in a shock-proof manner; see “Requirements” on page 22 in this chapter.

7 Installation

Have the following documents on hand before installation:

- Installation drawing for the axial piston unit (can be obtained from your contact person at Bosch Rexroth)
- Hydraulic circuit diagram for the axial piston unit (in the installation drawing)
- Hydraulic circuit diagram for the machine/system (available from the machine/system manufacturer)
- Order confirmation (contains the order-related technical data for your axial piston unit)
- Data sheet for the axial piston unit (contains the permissible technical data)

7.1 Unpacking

The axial piston unit comes in a polyethylene (PE) corrosion protection film.

CAUTION! Danger from parts falling out!

Improperly opening the packaging can result in parts falling out, which can be damaged or cause injury!

- ▶ Place the packaging on a level, load-bearing surface.
- ▶ Only open the packaging from the top.

- ▶ Remove the packaging from the axial piston unit.
- ▶ Check the axial piston unit for transport damage and completeness; see chapter 4 “Scope of delivery” on page 17.
- ▶ Dispose of the packaging in accordance with the regulations in your country.

7.2 Installation conditions

The installation position and location of the axial piston unit essentially determine how it is installed and commissioned (such as when filling and air bleeding the axial piston unit).

- ▶ Install the axial piston unit so that the expected forces and torque can be transferred without any danger. The machine/system manufacturer is responsible for sizing the fasteners.
- ▶ Observe the maximum permissible radial forces on the drive shaft when transferring input/output drive with radial loading (belt drives). If necessary, store the belt pulley separately.
- ▶ Make sure that the axial piston unit is air bled and filled with hydraulic fluid during commissioning and operation. Also do this also after relatively long standstill periods, since the axial piston unit may drain out through the hydraulic lines.
- ▶ Direct the leakage in the housing area to the reservoir through the highest drain port. Use a line size appropriate for the port.

- ▶ Avoid using a check valve in the drain line.
Exception: above-reservoir installation, drive shaft up.
A check valve in the drain line (cracking pressure 0.5 bar) can prevent the system from draining through the drain line. Please note the correct flow direction.
- ▶ To keep noise levels low, use elastic elements to isolate all connecting lines from all vibration-capable components (e.g. reservoir).
- ▶ Make sure that the drain line and return line flow into the reservoir below the min. fluid level in all operating conditions. This prevents foaming.
- ▶ Make sure that the working environment at the installation site is completely free of dust and foreign substances. The axial piston unit should be clean when installed. Contamination of the hydraulic fluid can considerably affect the function and service life of the axial piston unit.
- ▶ Use fiber-free cloths for cleaning.
- ▶ Use suitable, mild cleaning agents to remove lubricants and other heavy contamination. Do not allow cleaning agents to enter into the hydraulic system.

7.3 Installation position

The axial piston unit can be installed in the following positions. The pipeline routing shown illustrates the basic layout.

7.3.1 Below-reservoir installation (standard)

Below-reservoir installation means that the axial piston unit is installed outside of the reservoir and below the min. fluid level of the reservoir.



Recommended installation position: 1 and 2.

Also be sure to bleed air through air bleed port **R** when installing with the drive shaft up (special version).

Do not install the A2FE and A2FMT with the drive shaft up.

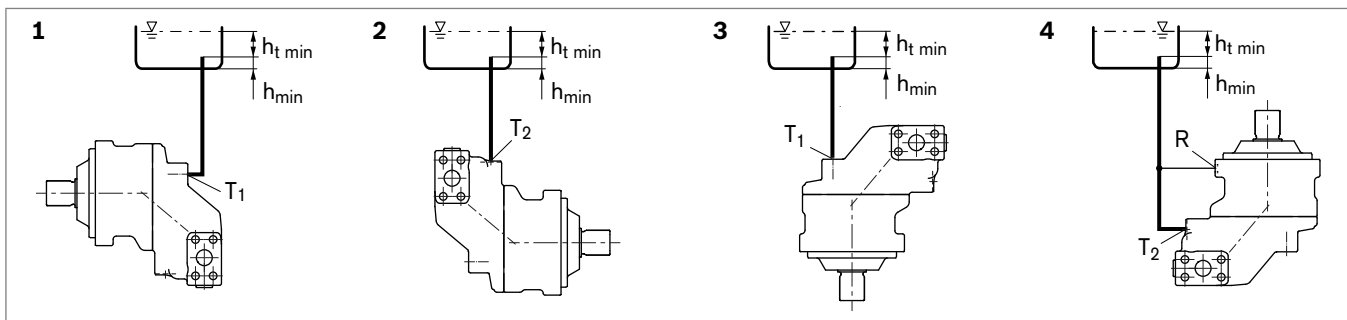

Fig. 6: A2FM below-reservoir installation with installation positions 1-4

T_1, T_2 Highest drain port

h_{min} Min. required distance to reservoir bottom (100 mm)

$h_{t\ min}$ Min. required immersion depth (200 mm)

Table 11: Below-reservoir installation

Installation position	Air bleed	Filling
1 (drive shaft horizontal)	–	T ₁
2 (drive shaft horizontal)	–	T ₂
3 (drive shaft down)	–	T ₁
4 (drive shaft up)	R	T ₂

7.3.2 Above-reservoir installation

Above-reservoir installation means that the axial piston unit is installed above the min. fluid level of the reservoir.



Also be sure to bleed air through air bleed port **R** when installing with the drive shaft up (special version).

Do not install the A2FE and A2FMT with the drive shaft up.



Recommendation for installation position **8** (drive shaft up): A check valve in the drain line (cracking pressure 0.5 bar) can prevent the housing area from draining.

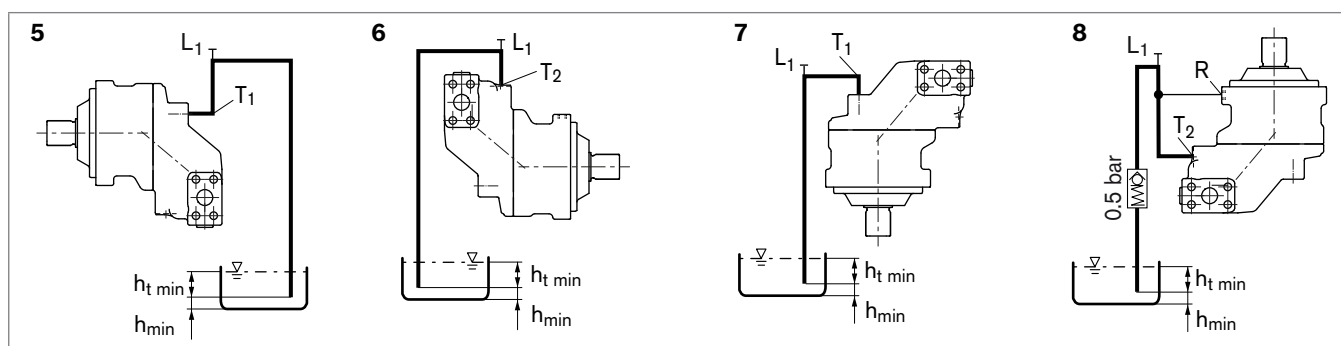

Fig. 7: A2FM above-reservoir installation with installation positions 5-8

- T₁, T₂ Highest drain port
- L₁ Filling/air bleeding
Notice: L₁ is part of the external piping
- h_{t min} Min. required immersion depth (200 mm)
- h_{min} Min. required distance to reservoir bottom (100 mm)

Table 12: Above-reservoir installation

Installation position	Air bleed	Filling
5 (drive shaft horizontal)	–	T ₁ (L ₁)
6 (drive shaft horizontal)	–	T ₂ (L ₁)
7 (drive shaft down)	–	T ₁ (L ₁)
8 (drive shaft up)	R	T ₂ (L ₁)

7.4 Installing the axial piston unit

7.4.1 Preparation

1. Check the specifications on the name plate to see you have the correct axial piston.
2. Compare the material number and designation (type code) with the details in the order confirmation.



If the material number for the axial piston unit does not match the one in the order confirmation, contact your local contact person for clarification. You can find their contact information under www.boschrexroth.com/addresses

3. Before installing, completely drain the axial piston unit to prevent mixing with the hydraulic fluid used in the machine/system.
4. Check the permissible direction of rotation of the axial piston unit (on the name plate) and make sure that this corresponds to the direction of rotation of the intended motor function.

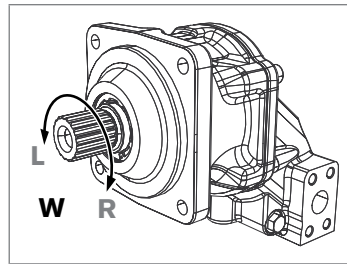

Fig. 8: Direction of rotation

- W** Bi-directional (can rotate counterclockwise and clockwise)
L Counterclockwise
R Clockwise



The direction of rotation as indicated on the name plate determines the direction of rotation of the axial piston unit as viewed on the drive shaft; see chapter 5.3 “Product identification” on page 19. For information on the direction of rotation of the drive motor, please refer to the drive motor manufacturer's instruction manual.

7.4.2 Dimensions

The installation drawing contains the dimensions for all connections and ports on the axial piston unit. Also observe the manuals provided by the manufacturers of the other hydraulic components when selecting the required tools.

7.4.3 General instructions

Follow these general instructions when installing the axial piston unit:

- If a shared drain line is used for several units, make sure that the case pressure in each unit is not exceeded. The shared drain line must be sized to ensure that the maximum permissible case pressure of all connected units is not exceeded in any operating conditions, particularly on cold start. If this is not possible, lay separate drain lines, if necessary.

How the axial piston unit is installed depends on the connecting elements to the output side. The following descriptions explain the installation of the axial piston unit:

- With a clutch
- On a gearbox

7.4.4 Installation with a clutch

The following describes how to install the axial piston unit with a clutch:

NOTICE! Danger from improper handling!

Product can be damaged!

- ▶ Do not install the clutch hub on the drive shaft of the axial piston unit by striking it.

1. Install the specified clutch half on the drive shaft of the axial piston unit according to the instructions of the clutch manufacturer.



The drive shaft of the axial piston unit is equipped with a female thread. Use this female thread to pull the clutch element onto the drive shaft. The size of the female thread can be seen in the installation drawing.

2. Clamp the clutch hub onto the drive shaft or ensure permanent lubrication of the drive shaft. This prevents the formation of frictional corrosion and the associated wear.
3. Transport the axial piston unit to the installation location.
4. Remove dirt and foreign particles from the installation location.
5. Install the clutch on the drive shaft of the machine in accordance with the specifications provided by the clutch manufacturer.



Do not fasten down the axial piston unit until the clutch has been correctly installed.

6. Fasten the axial piston unit at the installation location.
7. Align the drive shaft of the axial piston unit and the drive shaft of the machine so that there is no angular deviation.

8. Make sure that no excessive axial and radial forces are acting on the drive shaft.
9. Details on the required tools and tightening torques for the mounting bolts are available from the machine/system manufacturer.
10. When using flexible clutches, check that the drive is free of resonance after completing the installation.

7.4.5 Installation on a gearbox

The following describes how to install the axial piston unit on a gearbox.

After installing on a gearbox, the axial piston unit is covered and is difficult to access:

- ▶ Before installing, make sure that the spigot diameter centers the axial piston unit (observe tolerances) and that no excessive axial or radial forces are acting on the drive shaft of the axial piston unit (installation length).
- ▶ Protect the drive shaft against frictional corrosion by providing permanent lubrication.
- ▶ Fasten the axial piston unit at the installation location.

For attachment via gear wheel or helical gear shaft

No gearing forces higher than the maximum permissible axial and radial forces should act on the shaft; if necessary, support the gear wheel at the gearbox output separately.

7.4.6 Completing installation

1. Remove any installed transport screws.

CAUTION! Operation with protective plugs!

Operating the axial piston unit with protective plugs may result in injury or damage to the axial piston unit.

- ▶ Before commissioning, remove all protective plugs and replace them with suitable, pressure-resistant, metal threaded plugs or connect the appropriate lines.

2. Remove the transport protection.

The axial piston unit comes with protective covers **(1)** and protection plugs **(2)**.

They are not pressure-resistant and have to be removed prior to connection. Use a suitable tool for this to prevent damage to the sealing and functional surfaces.

If sealing or functional surfaces are damaged, contact your Bosch Rexroth service partner or the service department of the factory that manufactured the axial piston unit.

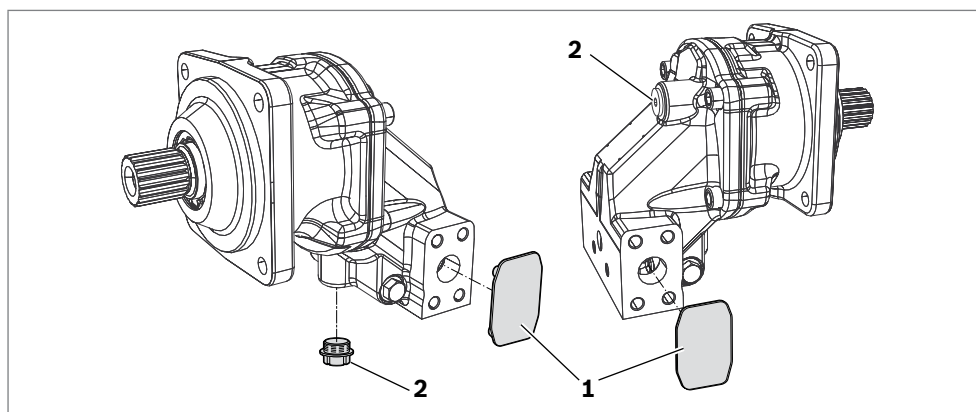

Fig. 9: Removing transport protection

1 Protective covers

2 Protective plugs/threaded plugs



Ports intended for connecting lines come with protective plugs or threaded plugs, which serve as transport protection. Connect all ports required for functional operation (see Table 15 Ports A2FM/A2FE/A2FMT series 70 on page 36). Failure to do so could lead to malfunctions or damage. If a port is not being used, plug it with a threaded plug since the protective plugs are not pressure-resistant.

The following information only applies to fixed motors with pressure relief valves.



Setting screws are protected against unauthorized adjustment by tamper-proof caps. Removal of the tamper-proof caps will void the warranty. If you need to change the settings, please contact your local contact person. You can find their contact information under www.boschrexroth.com/adresses

7.4.7 Hydraulically connecting the axial piston unit

The machine/system manufacturer is responsible for sizing the lines. Connect the axial piston unit to the rest of the hydraulic system in accordance with the hydraulic circuit diagram of the machine/system manufacturer.

The ports and fastening threads are designed for the maximum permissible pressures p_{\max} ; see Table 15 Ports A2FM/A2FE/A2FMT series 70 on page 36. The machine/system manufacturer should ensure that the connecting elements and lines correspond to the specified application conditions (pressure, flow, hydraulic fluid, temperature) with the necessary safety factors.



Connect only hydraulic lines that are appropriate for the axial piston unit port (pressure level, size, system of units).

Notices on routing lines

Observe the following information when routing the pressure and drain lines.

- Lines and hoses should be installed without pre-charge pressure, so that no further mechanical forces are applied during operation that will reduce the service life of the axial piston unit and, possibly, the entire machine/system.
- Use suitable seals as sealing material.
- Pressure line
 - For the pressure lines, use only pipes, hoses and connecting elements rated for the working pressure range specified in data sheets 91071 and 91072 (see Table 15).
- Drain line
 - Always route the drain lines so that the housing is constantly filled with hydraulic fluid and to ensure that no air gets through the shaft seal, even during extended standstill periods.
 - The case pressure should never exceed the max. limits specified for the axial piston unit in the data sheet.
 - The drain line inflow in the reservoir should always be below the min. fluid level (see chapter 7.3 “Installation position” on page 26).
- If the axial piston unit is equipped with installed screw fittings, do not remove them. Screw the stud end of the fitting directly into the installed fitting.

Risk of confusion with threaded connections

Axial piston units are used in application areas that use the metric system as well as the Anglo-American (imperial) and the Japanese measuring system (JIS – Japan Industrial Standard). Various kinds of seals are also used.

The system of units, the kind of seal and the size of female thread and stud ends (e.g. threaded plug) must all match.

There is a risk of confusion due to the limited ways of visually telling them apart.

WARNING! Leaky or bursting stud ends!

For fittings, if a stud end that does not match the system of units, kind of seal and size of the female thread is pressurized, the stud end may loosen itself or even be ejected from the hole in a projectile-like manner. This can result in serious injury and property damage. Hydraulic fluid can escape from this leakage point.

- ▶ Use the drawings (installation drawing) to determine the required stud end for each fitting.
- ▶ Make sure the right fittings, mounting bolts and threaded plugs are installed.
- ▶ For all female threads, use a stud end from the same system of units and of the correct size.

Connecting line to pressure relief valve with pressure sequencing stage (only for A2FM and A2FE)

Observe the following information on versions with pressure relief valves.

- ▶ When screwing in and tightening the connection line to the port P_{St} , hold the nut (1) on the pressure relief valve with pressure sequencing stage (2) using an AF 24 wrench. Observe the manufacturer's instructions regarding tightening torques for the connection line used. Do not exceed the maximum permissible tightening torque on the female thread (40 Nm).

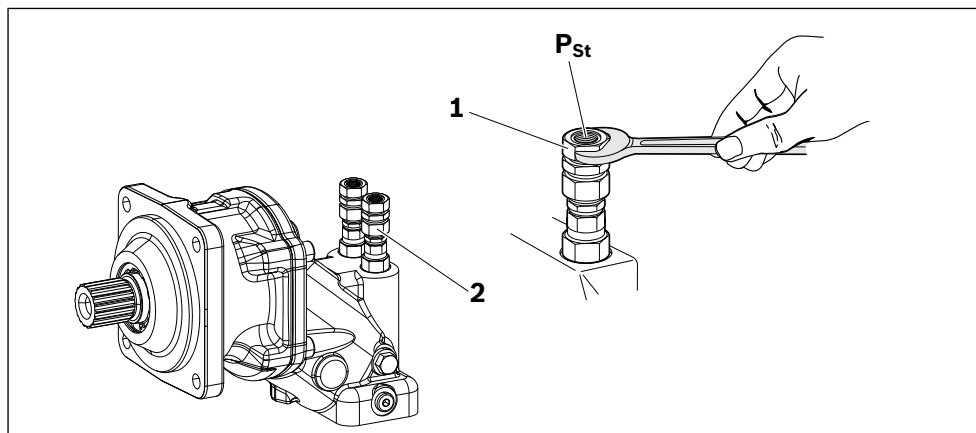

Fig. 10: Holding nut on pressure relief valve in place



Do not change the setting of the pressure relief valve. Adjusting the setting screw on the pressure relief valve will void the warranty.

Fastening the counterbalance valve (only for A2FM and A2FE)

Observe the following information on versions with counterbalance valves.

The counterbalance valve comes mounted to the motor with two tacking screws (transport lock). Do not remove the tacking screws when connecting the working lines. If the counterbalance valve and motor are delivered separately, the counterbalance valve must first be fastened to the motor housing using the tacking screws provided. The counterbalance valve is finally mounted to the motor by screwing on the SAE flange with the following bolts:

6 bolts (1, 2, 3, 4, 5, 8) Length B1 + B2 + B3

2 bolts (6, 7) Length B3 + B4

Tighten the bolts in two steps in the specified order from 1 to 8 (see Fig. 11).

- ▶ First, tighten the bolts to half the tightening torque, then tighten to the max. tightening torque (see table Table 13).

Table 13: Mounting bolt tightening torques

Thread	Property class	Tightening torque
M6 x 1 (tacking screw)	10.9	15.5 Nm
M10 x 1.5	10.9	75 Nm
M12 x 1.75	10.9	130 Nm

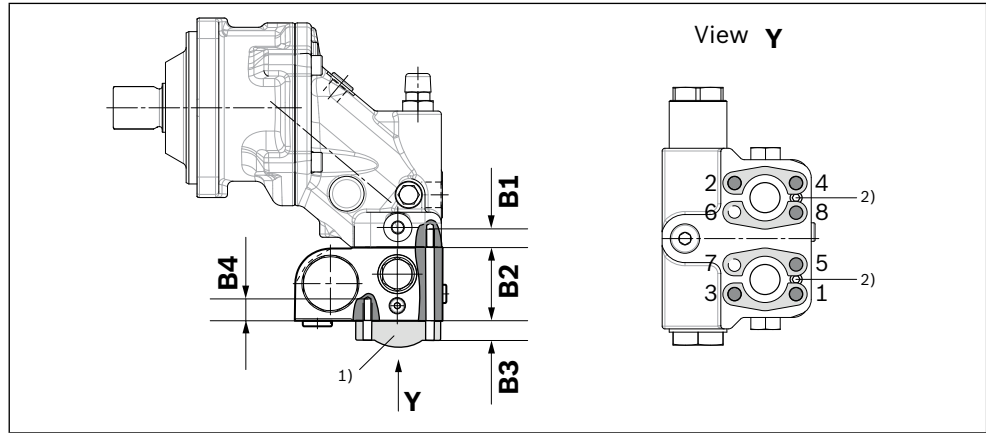

¹⁾SAE flange

²⁾Tacking screw (M6 x 1, length = B1 + B2, DIN 912)

Fig. 11: Mounting the counterbalance valve



The SAE flange and corresponding mounting bolts are not included in the scope of delivery.

Table 14: Thread sizes and dimensions

Size	56, 63	80, 90
Dimension B1 ¹⁾	M10 x 1.5 17 deep	M12 x 1.75 18 deep
Dimension B2	68 mm	68 mm
Dimension B3	Customer-specific (flange-dependent)	
Dimension B4	M10 x 1.5 15 deep	M12 x 1.75 16 deep

DIN 13 fastening thread For DIN 13 mounting bolts, we recommend checking the tightening torque on a case-by-case basis according to VDI 2230 Edition 2003.

¹⁾ Min. required thread reach 1 x Ø of thread

Port overview

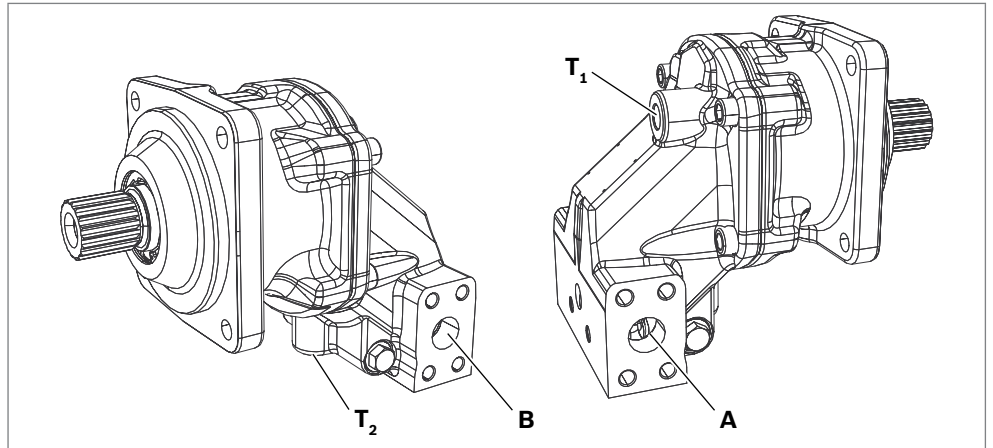

Fig. 12: A2FM port overview, lateral SAE working ports

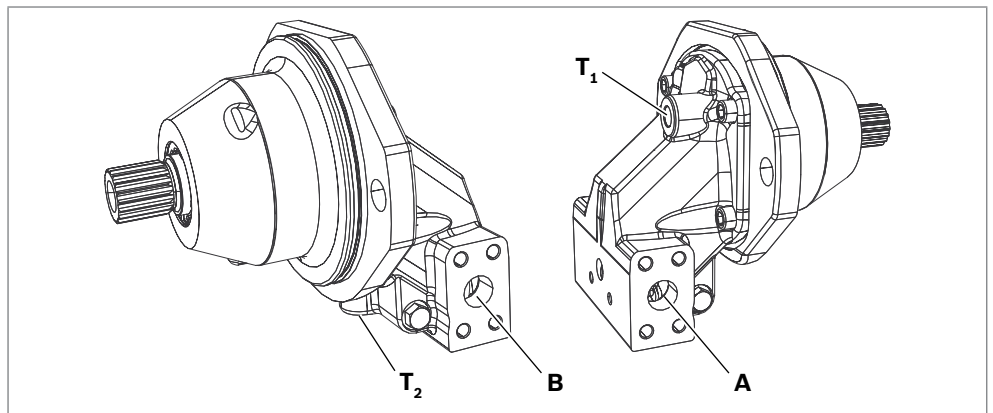

Fig. 13: A2FE port overview, lateral SAE working ports

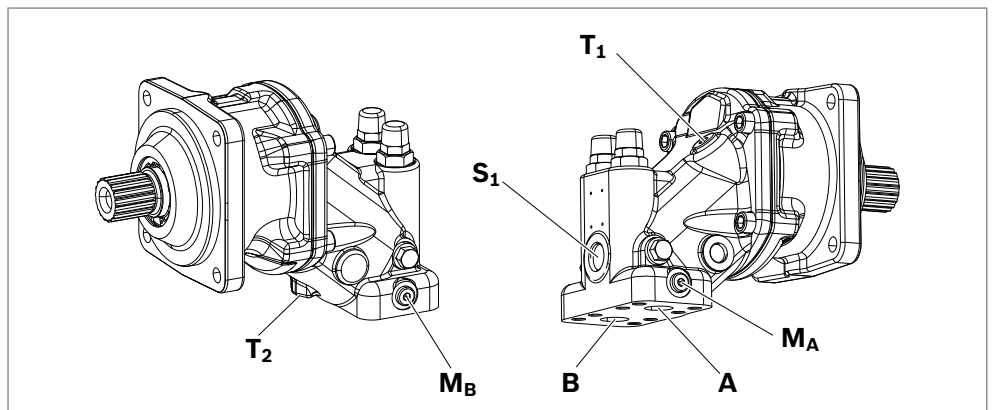

Fig. 14: A2FM port overview, bottom SAE working ports and pressure relief valve

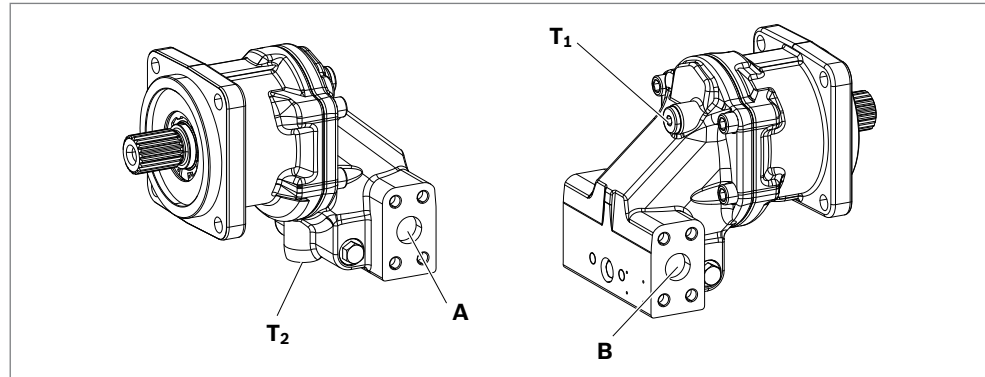

Fig. 15: A2FMT port overview, lateral SAE working ports and SAE mounting flange

Table 15: Ports A2FM/A2FE/A2FMT series 70

Ports ¹⁾		p_{\max} [bar] ²⁾				State
		A2FMN/ A2FEN	A2FMM/ A2FEM	A2FMH/ A2FEH	A2FMT	
A, B	Working port	350	450	500	420	O
T₁	Drain port	3	3	3	3	X ³⁾
T₂	Drain port	3	3	3	3	O ³⁾
S₁	Boost port (only on version with pressure relief valve)	–	5	–	–	O
M_A, M_B	A/B pressure measuring port (only on version with pressure relief valve)	–	420	–	–	X
P_{St}	Pilot pressure port (only on version with pressure relief valve and pressure sequencing stage)	–	30	–	–	O

¹⁾ The measuring system and thread size can be found in the installation drawing.

²⁾ Momentary pressure peaks may occur depending on the application. Keep this in mind when selecting measuring devices and fittings.

³⁾ Depending on the installation position, **T₁** or **T₂** must be connected (see chapter 7.3 “Installation position” on page 26).

O = Must be connected (comes plugged)

X = Plugged (in normal operation)

Tightening torques

The following tightening torques apply:

- Fittings:
 - Observe the manufacturer’s specifications regarding the tightening torques of the fittings used.
- Female threads in the axial piston unit:
 - The maximum permissible tightening torques $M_{G \max}$ are the max. values of the female threads and should not be exceeded. For values, see Table 16.
- Threaded plugs:
 - For the metallic threaded plugs supplied with the axial piston unit, the required tightening torques of threaded plugs M_V apply. For values, see Table 16.
- Mounting bolts:
 - For mounting bolts with metric ISO threads as defined in DIN 13 or threads defined in ASME B1.1, we recommend checking the tightening torque on a case-by-case basis in accordance with VDI 2230.

Table 16: Tightening torques for female threads and threaded plugs

Ports Standard	Thread size	Maximum permissible tightening torque of female threads $M_{G \max}$	Required tightening torque of threaded plugs M_V	WAF hexagon socket of the threaded plugs
DIN 3852	M8 × 1	10 Nm	7 Nm ¹⁾	3 mm
	M10 × 1	30 Nm	15 Nm ²⁾	5 mm
	M12 × 1.5	50 Nm	25 Nm ²⁾	6 mm
	M14 × 1.5	80 Nm	35 Nm ¹⁾	6 mm
	M16 × 1.5	100 Nm	50 Nm ¹⁾	8 mm
	M18 × 1.5	140 Nm	60 Nm ¹⁾	8 mm
	M22 × 1.5	210 Nm	80 Nm ¹⁾	10 mm
	M26 × 1.5	230 Nm	120 Nm ¹⁾	12 mm
	M27 × 2	330 Nm	135 Nm ¹⁾	12 mm
	M33 × 2	540 Nm	225 Nm ¹⁾	17 mm
	M42 × 2	720 Nm	360 Nm ¹⁾	22 mm
	M48 × 2	900 Nm	400 Nm ¹⁾	24 mm
ISO 11926	5/16-24 UNF-2B	10 Nm	7 Nm	1/8 in
	3/8-24 UNF-2B	20 Nm	10 Nm	5/32 in
	7/16-20 UNF-2B	40 Nm	18 Nm	3/16 in
	9/16-18 UNF-2B	80 Nm	35 Nm	1/4 in
	3/4-16 UNF-2B	160 Nm	70 Nm	5/16 in
	7/8-14 UNF-2B	240 Nm	110 Nm	3/8 in
	1 1/16-12 UN-2B	360 Nm	170 Nm	9/16 in
	1 5/16-12 UN-2B	540 Nm	270 Nm	5/8 in
	1 5/8-12 UN-2B	960 Nm	320 Nm	3/4 in
	1 7/8-12 UN-2B	1200 Nm	390 Nm	3/4 in

¹⁾ The tightening torques for the threaded plugs apply when the plugs are dry or lightly oiled.

²⁾ The tightening torques for the threaded plugs apply when the plugs are dry – when lightly oiled, the tightening torques for M10 × 1 are reduced to 10 Nm and to 17 Nm for M12 × 1.5.

- Procedure** To connect the axial piston unit to the hydraulic system:
1. Remove the protective plugs or threaded plugs from the ports where the connections should be made according to the hydraulic circuit diagram.
 2. Make sure that the sealing surfaces of the hydraulic ports and functional surfaces are not damaged.
 3. Use only clean hydraulic lines or flush them before installation. (Observe chapter 7.5 “Performing flushing cycle” on page 38 when you flush out the entire system.)
 4. Connect the lines in accordance with the installation drawing and the machine or system circuit diagram. Check whether all ports are connected or plugged with threaded plugs.
 5. Tighten the fittings correctly (note tightening torques!). Mark all correctly tightened fittings, e.g. with a permanent marker.
 6. Check all pipes and hose lines and every combination of connecting pieces, couplings or connecting points with hoses or pipes to ensure they are in safe working condition.



Relationship between direction of rotation and flow direction:

Clockwise rotation: **A to B**

Counter-clockwise rotation: **B to A**

7.5 Performing flushing cycle

In order to remove foreign particles from the system, Bosch Rexroth recommends a flushing cycle for the entire system before initial commissioning. To avoid internal contamination, do not include the axial piston unit in the flushing cycle.



Use an additional flushing unit to perform the flushing cycle. Follow the instructions of the flushing unit's manufacturer for the exact procedure during the flushing cycle.

8 Commissioning

WARNING

Danger while working in the danger zone of a machine/system!

Risk of death or serious injury!

- ▶ Pay attention to and eliminate potential danger sources before operating the axial piston unit.
- ▶ Make sure no one is in the danger zone of the machine/system.
- ▶ The emergency stop button for the machine/system should be within the operator's reach.
- ▶ Always follow the instructions of the machine/system manufacturer during commissioning.

CAUTION

Commissioning an improperly installed product!

Risk of injury and property damage!

- ▶ Make sure that all electrical and hydraulic ports are connected or plugged.
- ▶ Only commission a completely installed, fully functioning product with original accessories from Bosch Rexroth.

8.1 Initial commissioning



During all commissioning work on the axial piston unit, observe the general safety instructions and intended use detailed in chapter 2 "Safety instructions" on page 8.

- ▶ Connect the pressure gauge for the working pressure and case pressure to the specified measuring points on the axial piston unit or in the hydraulic system to check the technical data during the first operation.
- ▶ During commissioning, monitor the temperature of the hydraulic fluid in the reservoir to ensure that it lies within permissible viscosity limits.

8.1.1 Filling the axial piston unit

Professional filling and air bleeding is necessary to prevent damage to the axial piston unit and to maintain proper function.



Usually, the cleanliness level of commercial hydraulic fluids is insufficient for our components. These hydraulic fluids must be filtered using an appropriate filter system to minimize solid particle contamination and water in the system.

Use only a hydraulic fluid that conforms to the following requirements:

You can find details of the min. requirements on hydraulic fluids in Bosch Rexroth data sheets 90220 and 90221. The titles of the data sheets can be found in Table 1 “Required and supplementary documentation” on page 5. You can find details of permissible and optimal viscosity in data sheets 91071 and 91072.

To ensure the functional reliability of the axial piston unit, the hydraulic fluid must have a min. cleanliness level of 20/18/15 as defined in ISO 4406. At a hydraulic fluid viscosity of less than 10 mm²/s (e.g. due to high temperatures during short-term operation) at the drain port, a min. cleanliness level of 19/17/14 as defined in ISO 4406 is required. For permissible viscosities and temperatures, see data sheets 91071 and 91072.

1. Place a drip tray under the axial piston unit to collect any hydraulic fluid that may leak.

NOTICE! Contaminated hydraulic fluid!

The cleanliness levels of commercial hydraulic fluid are usually insufficient for our components.

- ▶ Use a suitable filter system to filter hydraulic fluids during filling to minimize solid impurities and water in the hydraulic system.

2. Fill and air bleed the axial piston unit using the appropriate ports; see chapter 7.3 “Installation position” on page 26. Also fill the hydraulic lines of the system.

NOTICE! Risk of property damage due to inadequate lubrication!

Product can be damaged or destroyed!

- ▶ When using a shut-off valve in the drain line, make sure that the drive of the axial piston unit can only be started when the shut-off valves are open.

3. When using a shut-off valve in the drain line, only operate the axial piston unit when the shut-off valves are open.

8.1.2 Testing the hydraulic fluid supply

The axial piston unit should always have a sufficient supply of hydraulic fluid. For this reason, the supply of hydraulic fluid must be ensured at the start of the commissioning process.

When you test the hydraulic fluid supply, constantly monitor noise development and check the hydraulic fluid level in the reservoir. If the axial piston unit becomes louder (cavitation) or the drain fluid is discharged with bubbles, this is an indication that the axial piston unit is not being sufficiently supplied with hydraulic fluid.

For information on troubleshooting, see chapter 14 “Troubleshooting” on page 49.

To test the hydraulic fluid supply:

1. Allow the axial piston unit to run at low speed and without load. Pay attention to leaks and noises.
2. Check the axial piston unit’s drain line during the test. The drain fluid should be without bubbles.
3. Increase the load and check whether the working pressure rises as expected.
4. Perform a leak test to ensure that the hydraulic system is sealed and can withstand the max. pressure.
5. At max. working pressure, check the case drain pressure at port **T₁** or **T₂**. Refer to data sheets 91071 and 91072 for the permissible value.

8.1.3 Performing a functional test

WARNING

Improperly connected axial piston unit!

Mixing up the ports will lead to malfunctions (e.g. lift instead of lower) and associated hazards to persons and equipment!

- ▶ Before the functional test, check whether the piping specified in the hydraulic circuit diagram has been installed.

Once you have tested the hydraulic fluid supply, perform a functional test on the machine/system. The functional test should be performed according to the instructions of the machine/system manufacturer.

The axial piston unit is tested for functional capability and performance before delivery according to the technical data. During commissioning, make sure the axial piston unit was installed properly in the machine/system.

- ▶ After starting the drive motor, check in particular the specified pressures, e.g. working pressure, boost pressure and case pressure.
- ▶ Perform a leak test without and with load prior to normal operation.
- ▶ If necessary, disconnect the pressure gauge and plug the ports with the specified threaded plugs.

8.2 Running-in phase

NOTICE

Property damage due to insufficient viscosity!

Elevated hydraulic fluid temperature may excessively reduce viscosity and damage the product!

- ▶ Monitor the operating temperature during the running-in phase, e.g. by measuring the leakage temperature.
- ▶ Reduce the loading (pressure, rotational speed) of the axial piston unit if unacceptable operating temperatures and/or viscosities occur.
- ▶ Operating temperatures that are too high indicate faults that have to be analyzed and eliminated.

The bearings and sliding surfaces are subject to a running-in phase. The increased friction at the start of the running-in phase results in increased heat development which decreases with increasing operating hours. Volumetric and mechanical hydraulic efficiency is also greater until the running-in phase of about 10 operating hours is concluded.

To ensure that contamination in the hydraulic system does not damage the axial piston unit, Bosch Rexroth recommends the following after the running-in phase:

- ▶ After the running-in phase, have a hydraulic fluid sample analyzed for the required cleanliness level.
- ▶ Change the hydraulic fluid if the required cleanliness level is not reached. If a laboratory test is not carried out after the running-in phase, it is recommended to change the hydraulic fluid.

8.3 Recommissioning after standstill

Depending on the installation conditions and ambient conditions, changes may occur in the hydraulic system which make recommissioning necessary.

The following criteria may make recommissioning necessary:

- Air and/or water in the hydraulic system
 - Old hydraulic fluid
 - Other contamination
- ▶ Before recommissioning, proceed as described in chapter 8.1 “Initial commissioning” on page 39.

9 Operation

This product is a component which requires no settings or changes during operation. For this reason, this chapter of the manual does not contain any information on adjustment options. Use the product only within the performance range specified in the technical data. The machine/system manufacturer is responsible for the proper planning of the hydraulic system and its control system.

10 Maintenance and repair

NOTICE

Overdue inspection and maintenance work!

Risk of property damage!

- ▶ Perform the specified inspection and maintenance work at the intervals described in this manual.

10.1 Cleaning and care

NOTICE

Damage to seals and electrical system due to mechanical effects!

The jet of a high-pressure cleaner may damage the seals and electrical system of the axial piston unit!

- ▶ Do not point a high-pressure cleaner at sensitive components, e.g. shaft seal, electrical connections and components.

For cleaning and care of the axial piston unit, observe the following:

- ▶ Check whether all seals and plug-in connections are securely seated to ensure that no moisture can penetrate into the axial piston unit during cleaning.
- ▶ Use only water and, if necessary, a mild cleaning agent to clean the axial piston unit. Never use solvents or corrosive cleaning agents.
- ▶ Remove major external contamination and keep clean sensitive and important components, such as solenoids, valves, displays and sensors.

10.2 Inspection

In order for the axial piston unit to be reliable and long-lasting, Bosch Rexroth recommends inspecting the hydraulic system and axial piston unit on a regular basis, and documenting and archiving the following operating conditions:

Table 17: Inspection schedule

Task to be performed	Interval	
Hydraulic system	Check level of hydraulic fluid in the reservoir.	Daily
	Check the operating temperature under comparable load condition at the drain port and in the reservoir.	Weekly
	Conduct analysis of hydraulic fluid: Viscosity, aging and contamination	Yearly or every 2000 operating hours (whichever occurs first)
	Check filter. The replacement interval may vary depending on the degree of contamination of the hydraulic fluid. We recommend using a contamination indicator.	Yearly or every 1000 operating hours (whichever occurs first)
Axial piston unit	Check axial piston unit for leakage. Early detection of hydraulic fluid loss can help to find faults on the machine/system and rectify them. This is why Bosch Rexroth recommends always keeping the axial piston unit and system clean.	Daily
	Check axial piston unit for unusual noise development.	Daily
	Check fastening elements for tight seating. All fasteners have to be checked when the hydraulic system is switched off, depressurized and cooled down.	Monthly

10.3 Maintenance

The axial piston unit is low-maintenance when used as intended.

The service life of the axial piston unit is heavily dependent on the quality of the hydraulic fluid. For this reason, we recommend changing the hydraulic fluid at least once per year or every 2000 operating hours (whichever occurs first) or having it analyzed by the hydraulic fluid manufacturer or a laboratory to determine its suitability for further use.

The service life of the axial piston unit is limited to the service life of the bearings used. You can ask your local contact person about service life based on load cycle. You can find their contact information under www.boschrexroth.com/addresses. Based on these details, a maintenance interval should be determined by the system manufacturer for the replacement of the bearings and included in the maintenance schedule of the hydraulic system.

10.4 Repair

Bosch Rexroth offers a comprehensive range of services for the repair of Rexroth axial piston units.

Repairs on the axial piston unit and its assembled parts should only be performed by service centers certified by Bosch Rexroth.

- ▶ Only use original spare parts from Rexroth to repair the Rexroth axial piston units, otherwise the functional reliability of the axial piston unit cannot be guaranteed and the warranty will be voided.

For questions regarding repairs, contact your proper Bosch Rexroth service partner or the service department of the factory that manufactured the axial piston unit; see chapter 10.5 “Spare parts” on page 46.

10.5 Spare parts

CAUTION

Use of unsuitable spare parts!

Spare parts that do not meet the technical requirements specified by Bosch Rexroth can cause injury and property damage!

- ▶ Only use original spare parts from Rexroth to repair the Rexroth axial piston units, otherwise the functional reliability of the axial piston unit cannot be guaranteed and the warranty will be voided.

The spare parts lists for axial piston units are order-specific. When ordering spare parts, specify the material and serial number of the axial piston unit as well as the material numbers of the spare parts.

Address all questions regarding spare parts to your proper Bosch Rexroth Service partner or the service department of the factory that manufactured the axial piston unit.

Bosch Rexroth AG
Glockeraustraße 4
89275 Elchingen, Germany
Hotline +49 9352 405060

Spare parts can be found online at www.boschrexroth.com/eshop

For general inquiries, please contact your local contact person. You can find their contact information at

www.boschrexroth.com/addresses

11 Removal and replacement

11.1 Required tools

Removal can be performed using standard tools. No special tools are necessary.

11.2 Preparing for removal

1. Decommission the entire system as described in the instruction manual for the machine or system.
 - Relieve pressure in the hydraulic system according to the instructions of the machine or system manufacturer.
 - Make sure that the relevant system components are not under pressure or voltage.
2. Secure the entire system against being re-energized.

11.3 Removal

Proceed as follows to remove the axial piston unit:

1. Make sure you have the appropriate tools and wear personal protective equipment.
2. Allow the axial piston unit to cool down until it can be removed without danger.
3. For below-reservoir installation, before removing the axial piston unit from the entire system, seal the connection to the reservoir or drain the reservoir.
4. Place a drip tray under the axial piston unit to collect any hydraulic fluid that may leak.
5. Disconnect the lines and collect the escaping hydraulic fluid in the drip tray.
6. Remove the axial piston unit. Use a suitable lifting device.
7. Completely drain the axial piston unit.
8. Plug all openings.

11.4 Preparing the components for storage or further use

- ▶ Proceed as described in chapter 6.2 “Storing the axial piston unit” on page 22.

12 Disposal

Careless disposal of the axial piston unit, the hydraulic fluid and the packaging material can result in environmental pollution.

Observe the following when disposing of the axial piston unit:

1. Completely drain the axial piston unit.
2. Dispose of the axial piston unit and packaging material in accordance with the regulations in your country.
3. Dispose of the hydraulic fluid in accordance with the regulations of your country.
Also observe the applicable safety data sheet for the hydraulic fluid.
4. Disassemble the axial piston unit into its constituent parts for proper recycling.
5. For example, separate into the following:
 - Castings
 - Steel
 - Aluminum
 - Non-ferrous metal
 - Electronic waste
 - Plastic
 - Seals

13 Extension and conversion

Do not modify the axial piston unit or its assembled parts.



The warranty from Bosch Rexroth only applies to the delivered product configuration. The warranty will be voided if the unit is modified or extended.

14 Troubleshooting

Table 18 is intended to help you with troubleshooting. This table is not exhaustive. Issues may occur in practice that are not listed here.

Only authorized personnel may perform troubleshooting inside a safety area designated by the machine manufacturer.

14.1 How to troubleshoot

- ▶ Troubleshoot with reduced operating parameters when possible.
- ▶ Use a systematic and targeted approach, even when pressed for time. Random, indiscriminate removal could make it impossible to determine the original cause of a fault.
- ▶ First get a general idea of how your product works in conjunction with the entire system.
- ▶ Try to find out whether or not the product was working properly in conjunction with the entire system before the fault occurred.
- ▶ Try to determine any changes to the entire system in which the product is installed:
 - Were there any changes to the product's application conditions or operating range?
 - Has maintenance recently been carried out? Is there an inspection or maintenance log?
 - Have any changes (e.g. upgrades) or repairs been made to the overall system (machine/system, electronics, control) or to the product? If yes, what has been done?
 - Has the hydraulic fluid been changed?
 - Has the product or machine been used as intended?
 - How did the malfunction appear?
- ▶ Try to get a clear idea of the cause of the fault. Directly ask the (machine) operator.
- ▶ Document the work carried out.
- ▶ If you cannot rectify the fault, get in touch with one of the contact addresses found at:

www.boschrexroth.com/addresses.

14.2 Malfunction table

Table 18: Axial piston unit malfunction table

Malfunction	Possible cause	Remedy	
Unusual noises	Insufficient air bleeding of the hydraulic system	Fill the axial piston unit, suction line for the hydraulic pump and the reservoir	
		Completely air bleed the axial piston unit and hydraulic system	
		Check correct installation position	
	Output speed too high	Machine/system manufacturer: reduce output speed	
	Improper mounting of the axial piston unit	Check the mounting of the axial piston unit according to the specifications of the machine/system manufacturer (observe tightening torques)	
Increased, unusual vibration	Improper mounting of assembled parts, hydraulic lines or improper installation of the clutch	Mount assembled parts according to the information provided by the clutch or fitting manufacturer	
	Mechanical damage to the axial piston unit (e.g. bearing damage)	Replace axial piston unit Contact Bosch Rexroth Service	
No or insufficient pressure	Insufficient air bleeding of the hydraulic system	Fill the axial piston unit, suction line for the hydraulic pump and the reservoir	
		Check correct installation position	
Pressure/flow fluctuations or instabilities	Faulty mechanical output drive (e.g. defective clutch)	Contact machine/system manufacturer	
	Drive power too low	Contact machine/system manufacturer	
	Wear or mechanical damage to the axial piston unit	Replace axial piston unit	
		Contact Bosch Rexroth Service	
	Drive unit defective (e.g. hydraulic pump)	Contact machine/system manufacturer	
Rotational speed or torque cannot be reached	Insufficient flow in hydraulic pump	Check function of the hydraulic pump	
		Hydraulic fluid not in optimum viscosity range	Machine/system manufacturer: check temperature range and use suitable hydraulic fluid
		Wear or mechanical damage to the axial piston motor	Replace axial piston unit Contact Bosch Rexroth Service
	Wear or mechanical damage to the hydraulic pump	Replace hydraulic pump Contact Bosch Rexroth Service	
	Wrong direction of rotation	Check function of the hydraulic pump Machine/system manufacturer: check correct direction of rotation; see chapter 7.4.1 "Preparation" on page 28	

Table 18: Axial piston unit malfunction table

Malfunction	Possible cause	Remedy
Excessive temperature of hydraulic fluid and housing	Excessive inlet temperature at the axial piston unit	Machine/system manufacturer: inspect system, e.g. malfunction in the cooler, insufficient hydraulic fluid in the reservoir
	Incorrect setting or malfunction of the pressure relief valves	Optimize the adjustment of the axial piston unit pressure relief valves and the pressure limitation in the hydraulic system Contact Bosch Rexroth Service
	Axial piston unit worn	Contact machine/system manufacturer Replace axial piston unit, contact Bosch Rexroth Service

15 Technical data

The permissible technical data of your axial piston unit can be found in data sheets 91071 and 91072.

The data sheet can be found online at www.boschrexroth.com/mediadirectory

You can find further information in the Mobile Hydraulics online product catalog:
www.boschrexroth.com/axial-piston-motors

Order-related technical data for your axial piston unit can be found in the order confirmation.

16 Alphabetical index

▶ A		▶ I	
Abbreviations	7	Identification	19
Above-reservoir installation	27	Inspection	45
▶ B		Installation	25, 28
Below-reservoir installation	26	– Completing	30
▶ C		– General instructions	29
Care	44	– On a gearbox	30
Circuit		– On gearbox	30
– Closed	18	– Preparation	28
– Open	18	– With clutch	29
Cleaning	44	Installation conditions	25
Commissioning	39	Installation position	
– Initial	39	– Above-reservoir installation	27
Connecting		– Below-reservoir installation	26
– Hydraulic	31	Intended use	8
Control plate	18	▶ L	
Conversion	48	Layout	18
Corrosion protection	23	Lifting device	20
Corrosion protection film	23	Lifting strap	22
Cylinder	18	▶ M	
▶ D		Maintenance	44, 45
Designations	7	Malfunction table	50
Dimensions	20, 28	Motor function	19
Direction of rotation	28	▶ N	
Disposal	48	Name plate	19
Drive shaft	18	Notices	
▶ E		– General	29
Eye bolt	21	▶ O	
▶ F		Operation	43
Filling	40	▶ P	
Flushing cycle	38	Performance description	18
Functional description		Piston	18
– Motor function	19	Port overview	35
Functional test	41	Product description	18
		Property damage	14

▶ Q		
Qualification		9
▶ R		
Recommissioning		
– After standstill		42
Removal		47
– Performing		47
– Preparing		47
Repair		46
Replacement		47
Required documentation		5
Running-in phase		42
▶ S		
Safety instructions		8
– General		10
– Product-specific		11
– Signal word		6
Scope of delivery		17
Spare parts		46
Storage		20
Storage time		23
Storing		22
Symbols		6
▶ T		
Technical data		52
Tightening torques		36
Tool		47
Transportation		20
– By hand		21
– With eye bolt		21
– With lifting strap		22
Transporting		20
Transport protection		31
Troubleshooting		49
▶ U		
Unpacking		25
▶ W		
Warranty	16, 31, 48	
Weight		20
Working port		18

Bosch Rexroth AG

Glockeraustraße 4

89275 Elchingen

Germany

Phone: +49 7308 82-0

info.ma@boschrexroth.de

www.boschrexroth.com

Your local contact person can be found at:

www.boschrexroth.com/addresses